



STRONG. PROFESSIONAL. DESIGN.™  
SPECIFICATIONS

**Bath Basics™**  
**Washerless Two Valve**  
**Tub & Shower Faucets**  
Model 3921

**Standard Features**

- Minimum working input  
water pressure .....20 psi
- Maximum operating input  
water pressure .....80 psi
- Maximum pressure .....125 psi
- Maximum flow rate....2.5 gpm at 80 psi
- Shower flow rate .....2.5 gpm at 80 psi
- Tub filler rate.....9 gpm at 60 psi
- Maximum handle torque  
at 80 psi .....1.25 ft lbs
- Handles .....acrylic
- Finish.....chrome

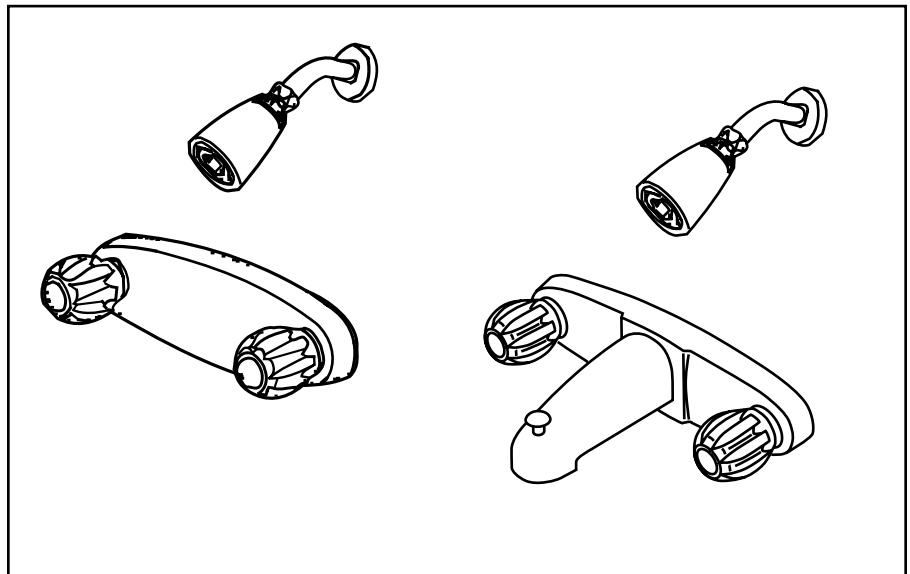

**Standards and Ratings**

- ASME A112.18.1M American Society of Mechanical Engineers Standard: "Plumbing Fixtures Fittings"

**Optional Features**

- Tub & Shower       Chrome
- Shower Only       Polished Brass
- Valve Only

**Features**

**Chrome plated**

**Handles**

**Washerless valves**

**Benefits**

Durable and easy to clean

Easy operation and unique style coordinates with traditional or contemporary decor

Proven drip-free performance

**Bath Basics™**  
**Washerless Two Valve**  
**Tub & Shower Faucets**  
 Model 3921

D I M E N S I O N S

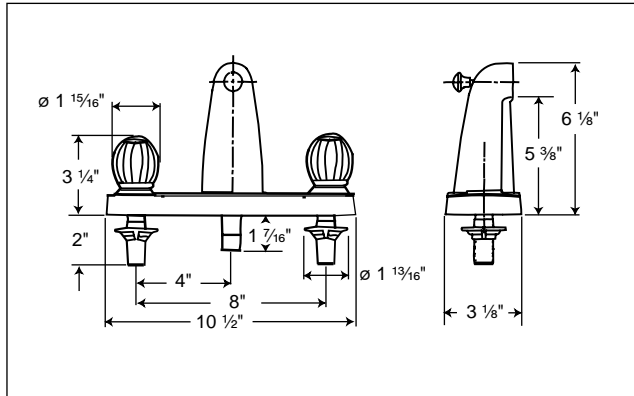

**Manufactured housing  
 tub and shower**

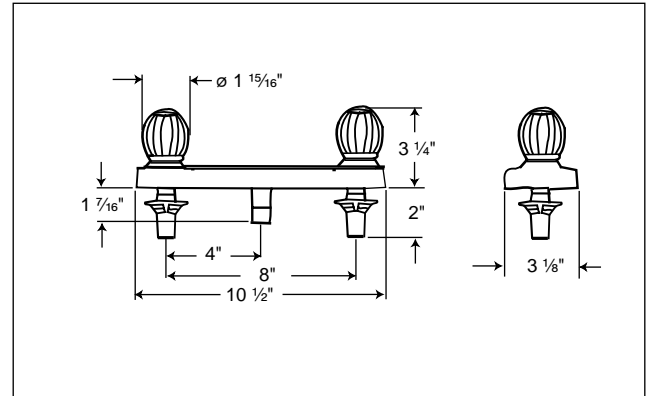

**Manufactured housing  
 shower only**

**SHOWER FLOWRATE (gpm)**

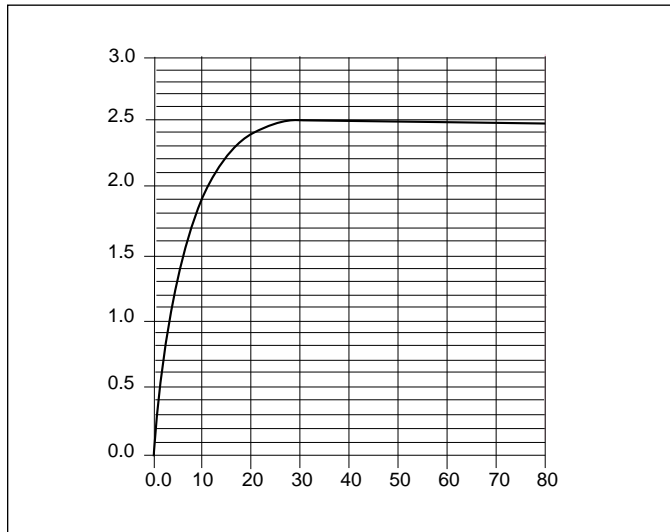

**LINE PRESSURE  
 P.S.I. GAUGE**

**TUB FILLER FLOWRATE (gpm)**

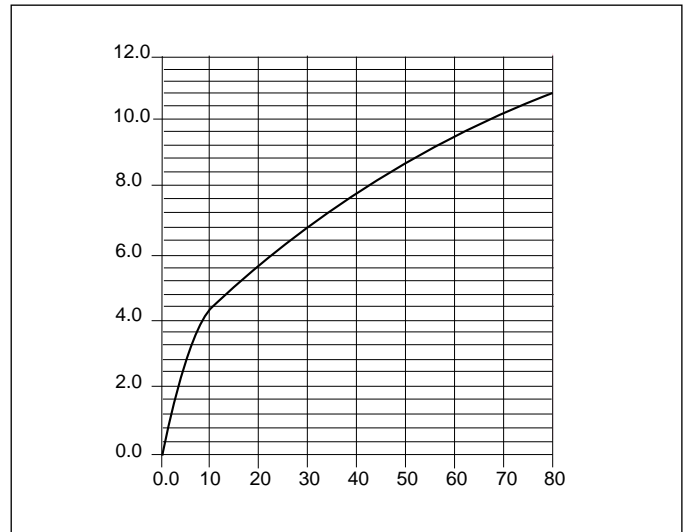

**LINE PRESSURE  
 P.S.I. GAUGE**

